

Alexander Kühn\*, Waldemar Raaz, Maximilian Karle, Thomas Rath

## **Development and evaluation of a system for objectively determining the quality of different types of turf**

---

Biosystems Engineering Laboratory – University of Applied Science Hochschule Osnabrück, Oldenburger Landstraße 24, 49090 Osnabrück, Germany;  
alexander.kuehn@hs-osnabrueck.de, waldemar.raaz@hs-osnabrueck.de,  
m.karle@hs-osnabrueck.de, t.rath@hs-osnabrueck.de

\* Correspondence: alexander.kuehn@hs-osnabrueck.de



**DGG-Proceedings 2025, Vol. 13**

Short Communications – Peer Reviewed, Open Access

Deutsche Gartenbauwissenschaftliche Gesellschaft e. V. (DGG)

German Society for Horticultural Science

[www.dgg-online.org](http://www.dgg-online.org)

Annual Conference DGG and BHGL

26.02.-01.03.2025, Essen, Germany

# Development and evaluation of a system for objectively determining the quality of different types of turf

Alexander Kühn, Waldemar Raaz, Maximilian Karle, Thomas Rath

University of Applied Science Hochschule Osnabrück, Germany

## Abstract

The sward density, the degree of cover, the weed-to-grass ratio and the homogeneity of the lawn are visual parameters that are indicative of the quality of a lawn. In common practice, even according to official guidelines, these are still recorded with the help of a frame meter square. This means that the assessment has a high subjective component. In order to enable objective recording and quantification when determining quality, a system was developed that allows conclusions to be drawn by means of camera recordings and image processing. The basic idea was based on the frame meter square and guaranteed consistent image quality through constant exposure conditions and standardized image settings. The images were processed by an image processing algorithm and enabled an evaluation of the different turf surfaces. Three sports fields and utility turfs were examined. Histograms and statistical key figures of soil, grass, and weed areas were determined as output parameters, which directly provide a quantified quality evaluation of the assessed turf area. The respective ratios and distributions of the parameters were able to reflect the sward density, the degree of cover, and the weed-to-grass ratio. However, it should be noted that the method described is an experimental research approach. The results presented are therefore to be considered preliminary; further investigations are needed to conclusively validate the methodology and ensure its reliability and validity under varying outdoor conditions.

## 1. Introduction

The quality of turf is regularly determined both in sports (e.g. football, golf) and in plant breeding companies in order to determine the degree of coverage, the weed-to-grass ratio or the visual and tactile impression (DFL 2022; FIFA 2023). The standard method is to use estimation frames in accordance with DIN EN 12231 (2003), which are time-consuming and often not sufficiently meaningful (Flachmann 2017; Flachmann and Müller-Beck 2017; Floß et al. 2021; Müller-Beck 2019). Digitalized measurement methods are still rare in turf science at the present time. However, turf vitality, which is a sub-area of quality determination, is often determined using a so-called greenseeker, which measures the Normalized Difference Vegetation Index (NDVI) value of the turf (Müller-Beck 2021). Another development for objective quality determination is the SigmaBox, a large aluminum box with integrated lighting, which is intended to ensure recordings under constant conditions. These images are evaluated using the SigmaScan software to obtain a value for the degree of plant cover (Karcher and Richardson 2005). The system and its evaluation are considered to be error-prone and only of limited use, as for example, no distinction is made between weeds and grasses. A pure clover area would also achieve a high degree of cover (Flachmann 2017; Flachmann and Müller-Beck 2017).

There are already various approaches to weed detection using image processing, but these are only of limited suitability. By calculating the grey-scale images of the colour channels of the RGB colour space, weeds are to be detected in lawns (Parra et al. 2019). A further development is the use of edge filters on each of the three gray value images (Parra et al. 2020).

Previous systems partially solve the quality determination of lawns but still show weaknesses. The aim of this study is:

- Develop an objective, global radiation-independent system for evaluating turf quality based on sward density, weed-to-grass ratio, and homogeneity.
- Transform traditional estimation frame analyses into a standardized, quantitative assessment method under controlled conditions.

## 2. Data, Methods and Approach

A photo box was developed. A truncated pyramid with a base area of 1.1 m by 1.1 m was selected as the type of construction in order to be able to take secured photos of an area of 1 m by 1 m. The camera used was a Sony DSC-RX100M5 with a resolution of 20 megapixels. Due to the focal length of the camera and the required recording area, a recording height of 1.2 m was selected. A ring light with 55 W and a CRI value of 95 was installed in the upper square. The truncated pyramid was lined with a light-coloured blackout fabric to reduce the transmission of external light as much as possible and to ensure a high level of light reflection within the wall. The top of the truncated pyramid was sealed with an aluminium composite panel in which the camera was framed.

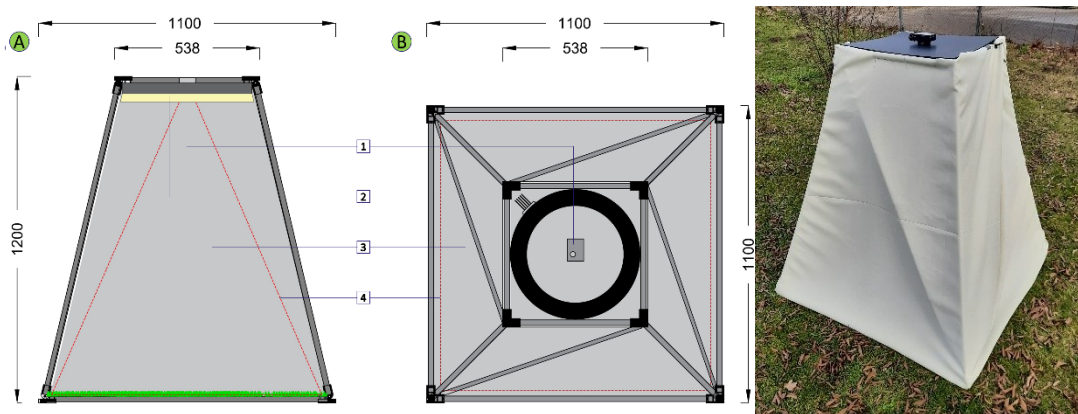

Figure 1: left: sketch of the side view (A) and top view (B) of the photo box with camera (1), LED ring light (2), blackout fabric (3) and camera angle or surface (4); dimensions in mm; right: photo of the photo box.

Using this system, three images were taken on different types of turf and processed and evaluated using a programmed algorithm based on the HALCON image processing software (MVTEC® 2025) which is shown in Figure 2.

- (1) To begin with, an RGB image was captured. This was cropped to a square so that the image section represented a lawn area of 1 m by 1 m. The square image section was then divided into the individual red, green, and blue channels.

- (2) From these, some known colour spaces and their channels were calculated and examined, which ensure the best differentiation between grasses and weeds and the ground. The HSV colour space with the individual channels Hue, Saturation and Value proved to be the best for this.
- (3) The pixel value ranges from 0 to 30 in the Hue channel made it possible to select the proportion of dry grass (straw) in the image. The intersection of the pixels from 130 to 255 in the Hue channel and from 0 to 170 in the Value channel was selected for the extraction of soil components.
- (4) After deleting the soil pixels from the image domain, the green sub-areas remained, which stood for vital grasses, yellowish grasses, and weeds. Edge detection was performed using the canny filter to highlight grass edges, leaf edges, and other structures in the image. After edge filtering, a binary edge image was generated.
- (5) Grasses and leaves had to lie within the edges so that an algorithm could be developed that searched for the largest possible circular area that could be placed in the areas between the edges. A large circle radius  $K$  was selected. The area found was written to a database,  $K$  was reduced and the algorithm was repeated until no new areas were found or the circular area was reduced to 1.5 times the average width of a blade of grass (10 pixels, for example). The areas stored in the database had to be weeds and could not belong to the grasses.
- (6) As only circles were entered, but weeds can have any conceivable shape, further image analysis steps had to be incorporated in order to separate the plant areas as precisely as possible into grass and weeds. For this purpose, the detected weed regions and the grass regions (edges) were continuously enlarged by dilation until the entire plant area was divided up.
- (7) After the entire algorithm had been carried out, the images contained regions that could be assigned to four areas: 1. soil regions, 2. straw regions, 3. weed regions, 4. grass regions. Their areas, their number, and their frequency distributions were condensed into feature vectors that were intended to reflect the quality of the turf. The degree of cover was calculated by summing up the number of pixels of the areas of grasses (dried and vital) and weeds. The weed-to-grass ratio was calculated by dividing the weed percentage by the grass percentage.

The algorithm presented was applied to images of three different lawns:

1. lawn with increased weed occurrence
2. lawn with high sward density and low weed cover
3. lawn with increased soil content

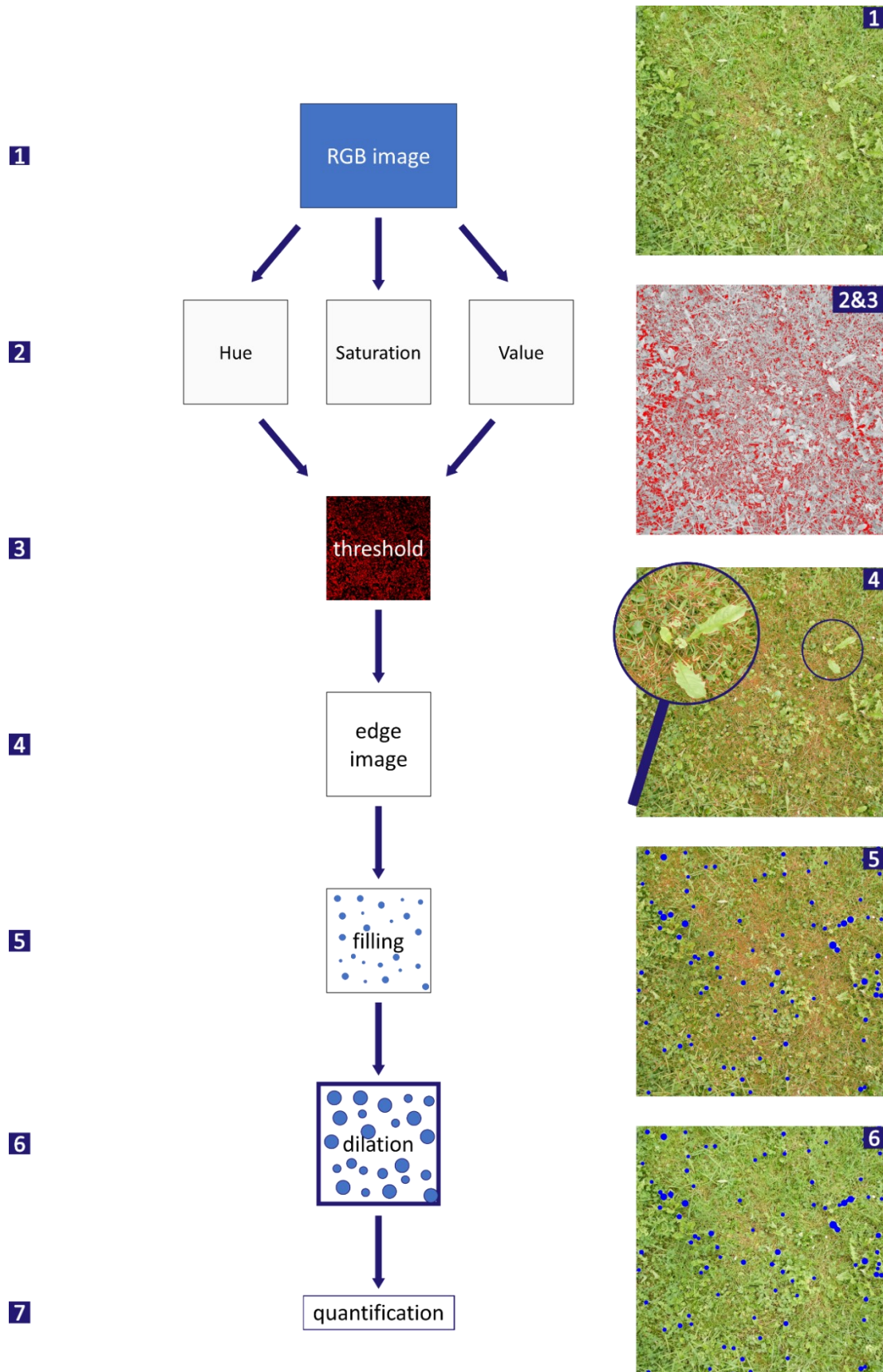

Figure 2: Schematic representation of the image processing algorithm (left) and its step-by-step application to a lawn image (right) with blue circles as weed dots. Not all weeds are detected, because weed structures generated edges in the edge detection procedure.

### 3. Results and Discussion

Figure 3 shows three images of different lawns with increased contents of weed (3A), turf (3B) and soil (3C) and below them the corresponding pie charts with the respective proportions of the four parameters calculated by the algorithm (3a, 3b, 3c). These show that a higher weed value could clearly be determined in Figure 3A. The soil only had a low proportion, as can also be seen in Table 1. The proportion of vital grasses was lowest in image 3A, but this had the highest proportion of dry grasses, resulting in a total grass proportion of over 92%. In contrast, virtually no weeds were detected in image 3B, which had a good lawn area. The proportion of soil was also very low, so that the proportion of grass and the degree of cover was the highest of the 3 images at 98%. A larger proportion of soil was recorded in image 3C, but below a value of 5%. The largest proportion was again made up of vital and dried grasses with a small proportion of weeds.

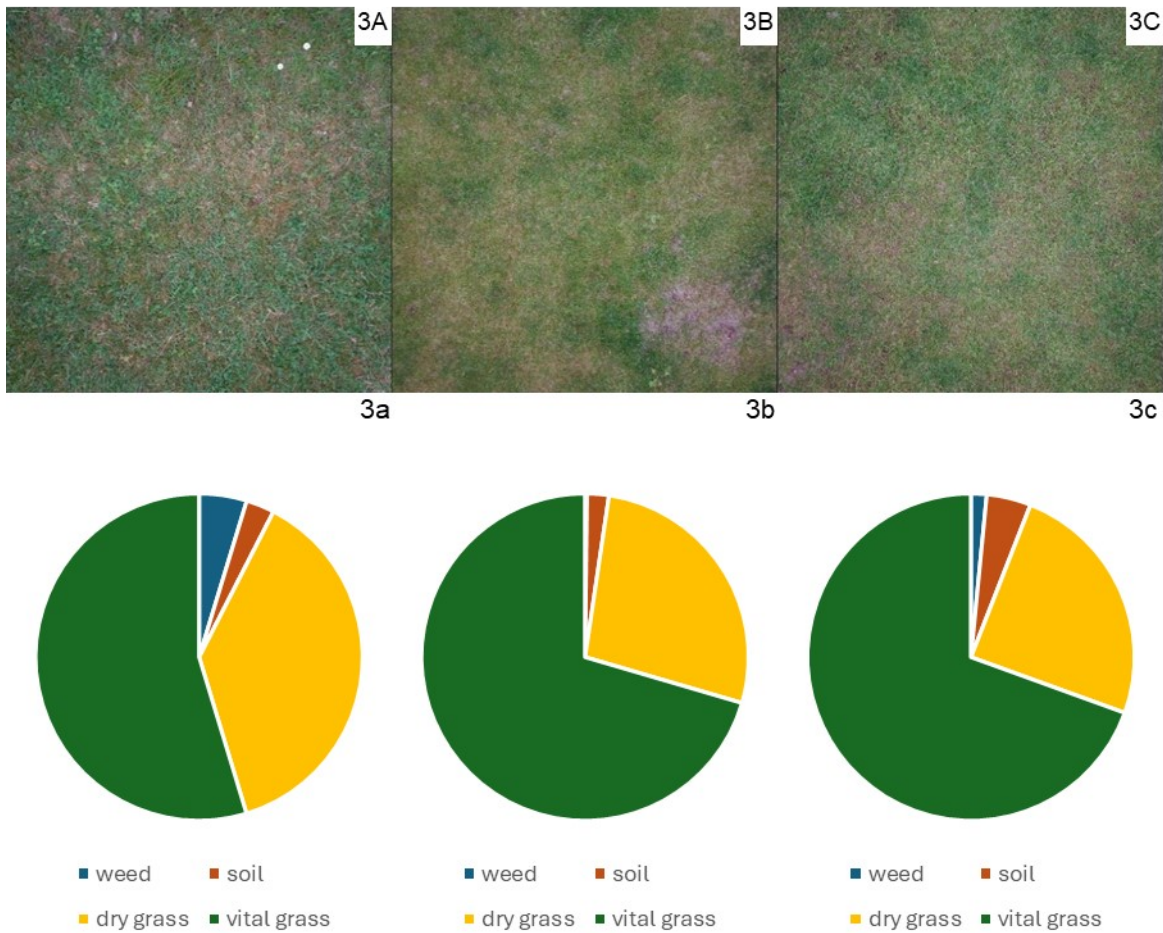

Figure 3: Images of the different turf types with increased weed cover (3A), good sward (3B) and increased soil content (3C) and the corresponding distributions of the four area proportions weed, soil, dry grass and vital grass.

Table 1: Percentage of the four calculated pixel areas as well as the total proportion of grasses (dry and vital), the grass/weed ratio and the degree of cover.

	Image 1	Image 2	Image 3
Weed	4.71	0.19	1.54
Soil	2.81	2.15	4.39
Dry grass	37.79	27.18	24.60
Vital grass	54.68	70.47	69.46
Grass proportion	92.47	97.65	94.07
Weed proportion	4.71	0.19	1.54
Weed-grass-ratio	0.05	0.00	0.02
Coverage	97.19	97.85	95.61

Initial visual inspections suggested that the soil content was higher than the algorithmic estimates. However, closer manual scoring revealed that most of these areas were covered with dried grass, confirming that the algorithm's classifications were, in fact, accurate. The weeds in the areas were not all fully detected, either because grasses were hanging over them, which reduced the leaf width and could no longer be recognized as weeds, or because the leaf veins of the weeds were pronounced, which caused them to be recognized as edges. The representativeness of the weed proportions determined must therefore be viewed critically. The dried grass was fully recognized in the images. The vital grasses were also recognized, but due to blurring at very high magnification of the images, misclassifications could still be observed in a few places.

#### 4. Conclusions

The system has demonstrated the required functionality by generating images that are independent of global radiation with constant exposure conditions. It has been successfully applied as a proof of concept on three different lawns. The quality assessment parameters of turf density and coverage and weed-to-grass ratio were successfully determined the weed-to-grass ratio must be viewed in a differentiated manner due to the fact that the weed area was not fully recorded. Because of limited lawn investigation areas these results are not statistically proven but show clear tendencies. Further improvement of the camera's optical resolution is desirable to eliminate misclassifications at the pixel level. Furthermore, it is necessary to examine whether the currently well-functioning algorithm can be further improved using local or global operators to achieve optimal recognition rates even with low-resolution images. The extent to which image processing operators such as Fast Fourier methods, which have already been successfully investigated for quality feature generation in lawns (Kühn et al. 2024), could be used in this process, cannot be estimated at this time. In any case, the number of test and training datasets must be further increased so that functioning deep learning AI models (Jin et al. 2022) can be integrated for the precise localization of weeds.

## Literature

DFL (2022) Qualitätssicherung für Stadionrasen - Arbeitsbuch für das Greenkeeping in der Bundesliga und 2. Bundesliga. Available online at [https://media.dfl.de/sites/2/2022/06/DE\\_DFL\\_Broschuere\\_Greenkeeping\\_Stadionrasen\\_Ansichts\\_PDF.pdf](https://media.dfl.de/sites/2/2022/06/DE_DFL_Broschuere_Greenkeeping_Stadionrasen_Ansichts_PDF.pdf) (Access 24-02-2026)

DIN (2003) DIN EN 12231 - Bestimmung der Bodendeckung bei Naturrasen. Berlin: Beuth Verlag GmbH

FIFA (2023) FIFA Natural-Pitch Rating System - Natural Playing Surfaces Quality Programme. Available online at [https://digitalhub.fifa.com/m/58aa765dd3e85f26/original/FIFA-natural-pitch-rating-system\\_EN.pdf](https://digitalhub.fifa.com/m/58aa765dd3e85f26/original/FIFA-natural-pitch-rating-system_EN.pdf) (Access 24-02-2026)

Flachmann KM (2017) Vergleichende Untersuchungen zur Bestimmung des Deckungsgrades auf Rasenflächen: Schätzrahmen vs. SigmaBox. *Rasen-Turf-Gazon* 48: 31-34

Flachmann KM, Müller-Beck K (2017) Deckungsgrad - ein Parameter zur Bestimmung der Rasenqualität. Available online at <https://www.rasengesellschaft.de/rasenthema-detailansicht/rasenthema-juli-2017.html> (Access 24-02-2026)

Floß A, Prämaßing W, Thieme-Hack M (2021) Bewertungsmethoden von Rasenqualität: Ein Vergleich zwischen subjektiven (Bonitur) und objektiven (Messung) Untersuchungsparametern. *Rasen-Turf-Gazon* 52: 10-13.

Jin X, Liu T, Chen Y, Yu J (2022) Deep Learning-Based Weed Detection in Turf: A Review. *Agronomy*, 12: 3051. <https://doi.org/10.3390/agronomy12123051>

Karcher DE, Richardson MD (2005) Batch Analysis of Digital Images to Evaluate Turfgrass Characteristics. *Crop Science* 45: 1536-1539. <https://doi.org/10.2135/cropsci2004.0562>

Kühn A, Raaz W, Karle M, Rath T (2024) Entwicklung und Anwendung einer Fourier-Analyse auf einem Rasenmäroboter zur Bewertung der Rasenqualität. In: *BHGL Schriftenreihe* 56: 49

Müller-Beck K (2019) Messwerte für die Qualitätsbestimmung von Golfgrüns. *Greenkeeper Journal* 40: 44-45

Müller-Beck K (2021) Messungen und Bonitur der Gräservitalität liefern Daten zur Rasenqualität. Available online at <https://www.rasengesellschaft.de/rasenthema-detailansicht/mai-2021-782.html> (Access 24-02-2026)

Parra L, Marin J, Yousfi S, Rincón G, Mauri PV, Lloret J (2020) Edge detection for weed recognition in lawns. *Computers and Electronics in Agriculture* 176: 105684. <https://doi.org/10.1016/j.compag.2020.105684>

Parra L, Torices V, Marin J, Mauri PV, Lloret J (2019) The use of image processing techniques for detection of weed in lawns. In: *IARIA ICONS 2019: The Fourteenth International Conference on Systems*: 50-55.